

Table of Contents

1. Introduction	34
1.1 Use of the manual	35
1.2 Guarantee terms	35
1.3 Copyright	35
2. Safety Instructions	36
3. Installation	38
3.1 Package content	38
3.2 Tower configuration setup	39
3.2.1 UPS	39
3.2.2 UPS + battery cabinet (optional)	40
3.3 Rack configuration setup	41
3.4 Rear panel	43
3.5 Installation procedure	44
4. Operation	45
4.1 Control Panel	45
4.1.1 LCD Panel	45
4.1.2 Display description	46
4.2 Operating modes	47
4.3 Start-up procedure	48
4.3.1 Normal mode	48
4.3.2 Cold start	48
4.4 Shutdown	49
4.5 UPS Measurements	49
4.6 UPS settings	50
4.7 Settings shortcuts	55
4.8 Emergency Power Off (EPO)	55
4.9 Communication devices	56
5. Troubleshooting	57
6. Warehousing and dismantling	59
6.1 Warehousing	59
6.2 Dismantling	59
7. Technical specifications	60
8. Battery replacement	62

Congratulations on your recent LEGRAND purchase!

ATTENTION

It is necessary to read the whole manual carefully before doing any operation.
DAKER DK Plus must be used only in residential, commercial industrial environments.

The following diagram illustrates the architecture of the UPS system:

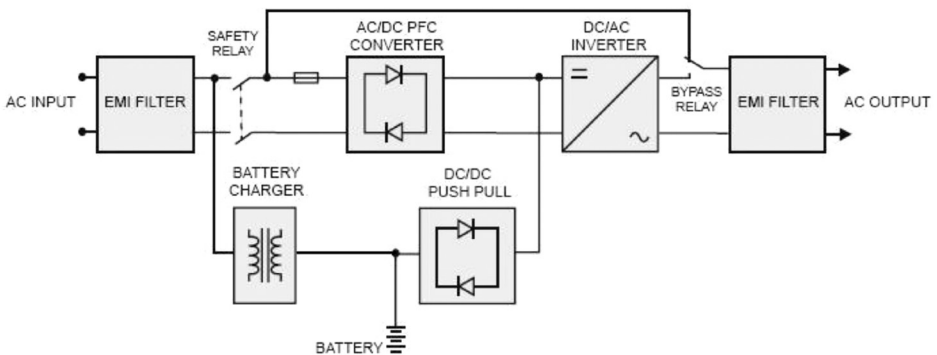

The major modules consist of:

- An AC-to-DC power converter (rectifier) with PFC control circuit.
- A DC-to-AC high frequency inverter.
- A battery charger.
- A battery bank.
- A DC-to-DC push/pull converter control circuit.
- A static bypass loop.
- Input and output EMI filters.

1.1 Use of the manual

This manual must be kept in a safe, dry place and must always be available for consultation.

The manual reflects the state of the art when the equipment was put onto the market. This publication conforms to the standards current on that date; the manual cannot be considered inadequate when new standards come into force or modifications are made to the equipment.

The version of the manual updated to its latest release is available on the Internet from the website <http://www.ups.legrand.com>

INDICATION

The installation manual is an integral part of the equipment supplied and must therefore be kept for its entire lifetime. In case of need (for example in the case of damage that even partially compromise its consultation) a new copy must be requested from the Manufacturer, quoting the publication code on the cover.

1.2 Guarantee terms

The terms of the guarantee may vary depending on the country where the UPS is sold. Check the validity and duration with LEGRAND's local sale representative.

The Manufacturer declines all indirect or direct responsibility arising from:

- failure to observe the installation instructions and use of the equipment which differs from the specifications in the installation manual;
- use by personnel who have not read and thoroughly understood the content of the installation manual;
- use that does not comply with the specific standards used in the country where the equipment is installed;
- modifications made to the equipment, software, functioning logic unless they have been authorized by the Manufacturer in writing;
- repairs that have not been authorized by the LEGRAND Technical Support Service;
- damage caused intentionally, through negligence, by acts of God, natural phenomena, fire or liquid infiltration.

1.3 Copyright

The information contained in this manual cannot be disclosed to third parties. Any partial or total duplication of the manual which is not authorized in writing by the Manufacturer, by photocopying or other systems, including by electronic scanning, violates copyright conditions and may lead to prosecution.

LEGRAND reserves the copyright of this publication and prohibits its reproduction wholly or in part without previous written authorisation.

2 Safety Instructions

This section contains important safety instructions that should always be followed during the installation, use and maintenance of the UPS.

- This product should be installed in compliance with installation rules, preferably by a qualified electrician. Incorrect installation and use can lead to risk of electric shock or fire. Before carrying out the installation, read the instructions and take account of the product's specific mounting location. Do not open up, dismantle, alter or modify the device except where specifically required to do so by the instructions. All Legrand products must be opened and repaired exclusively by personnel trained and approved by Legrand. Any unauthorised opening or repair completely cancels all liabilities and the rights to replacement and guarantees. Use only Legrand brand accessories.
- If any visible damage is found on the product during the unpacking operation, do not install the UPS but repack the unit and return it to your reseller or distributor.
- Before operating the UPS or connecting any load equipment, ensure the UPS is connected to a properly grounded electrical supply.
- The load applied must not exceed the one indicated on the type label of the UPS.
- The ON/OFF button of the UPS does not electrically isolate the internal parts. To isolate the UPS, unplug it from the mains power socket.
- Do not attempt to open or disassemble the UPS; there are no user replaceable parts. Opening the case will void the warranty and introduces the risk of electric shock even when the mains plug is disconnected.
- The mains socket outlet that supplies the UPS shall be installed near the UPS and shall be easily accessible.
- Do not plug non-computer-related items such as medical, life-support and house electric equipments to the UPS output.
- Do not plug laser printers to the UPS output because they have a high start-up current.
- The UPS has its own internal energy source (batteries). If the UPS is switched on when no AC power is available, there is hazardous voltage at the output sockets.



The batteries inside the UPS are not user-replaceable. Servicing of batteries must be performed only by electrical hazard authorized personnel.



CAUTION: A battery can present a risk of electrical shock and high short circuit current. The following precautions should be observed when working on batteries:

- a) Remove watches, rings or other metal objects.
- b) Use tools with insulated handles.
- c) Wear rubber gloves and boots.
- d) Do not lay tools or metal parts on top of batteries.
- e) Disconnect the charging source prior to connecting or disconnecting battery terminals.
- f) Determine if battery is inadvertently grounded. If inadvertently grounded, remove source from ground. Contact with any part of a grounded battery can result in electrical shock.

DAKER DK Plus

1 kVA - 2 kVA - 3 kVA

The likelihood of such shock can be reduced if such grounds are removed during installation and maintenance (applicable to equipment and remote battery supplies not having a grounded supply circuit).



CAUTION: Do not dispose of batteries in a fire. The batteries may explode.



CAUTION: Do not open or mutilate batteries. Released electrolyte is harmful to the skin and eyes. It may be toxic.

- This UPS has dangerous high voltages on its input and output connections. Contact with these voltages may be life threatening.
- In case of emergency, immediately turn off the equipment and disconnect the power cord from the AC power supply to disable the UPS.
- Do not allow any liquid or any foreign object to enter the UPS.
- The UPS is intended for indoor installation in a ventilated, controlled indoor environment with a range of temperature between 0°C (+32°F) and +40°C (+104°F) and non-condensing humidity between 20% and 80%.
- Do not install the UPS in locations with sparks, smoke and hazardous gas or where there is water and excessive humidity. Dusty, corrosive, and salty environments can damage the UPS.
- Do not plug the UPS input into its own output.
- Do not attach a power strip or surge suppressor to the UPS.
- Do not cover the cooling vents and keep a clearance of 20 cm beyond the UPS rear panel. Avoid exposing it to direct sunlight or installing it near heat emitting appliances.
- Unplug the UPS prior to cleaning and do not use liquid or spray detergent.
- Do not place the UPS near equipments that generate strong electromagnetic fields and/or near equipments that are sensible to electromagnetic fields.



WARNING

All the UPSs are category C2 products according to the EN 62040-2. In a residential environment, these equipments may cause radio interference, in which case the user may be required to take additional measures.

3.1 Package content

Check for the following package content:

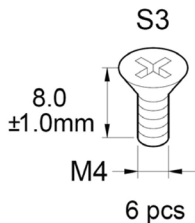
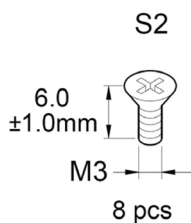
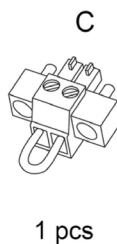
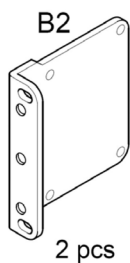
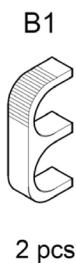
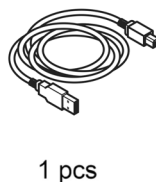
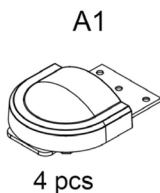
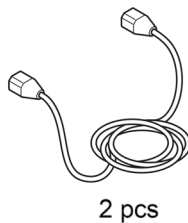
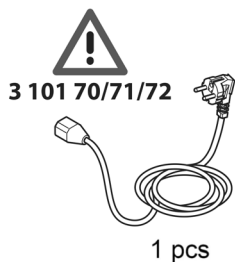

3.2 Tower configuration setup

3.2.1 UPS

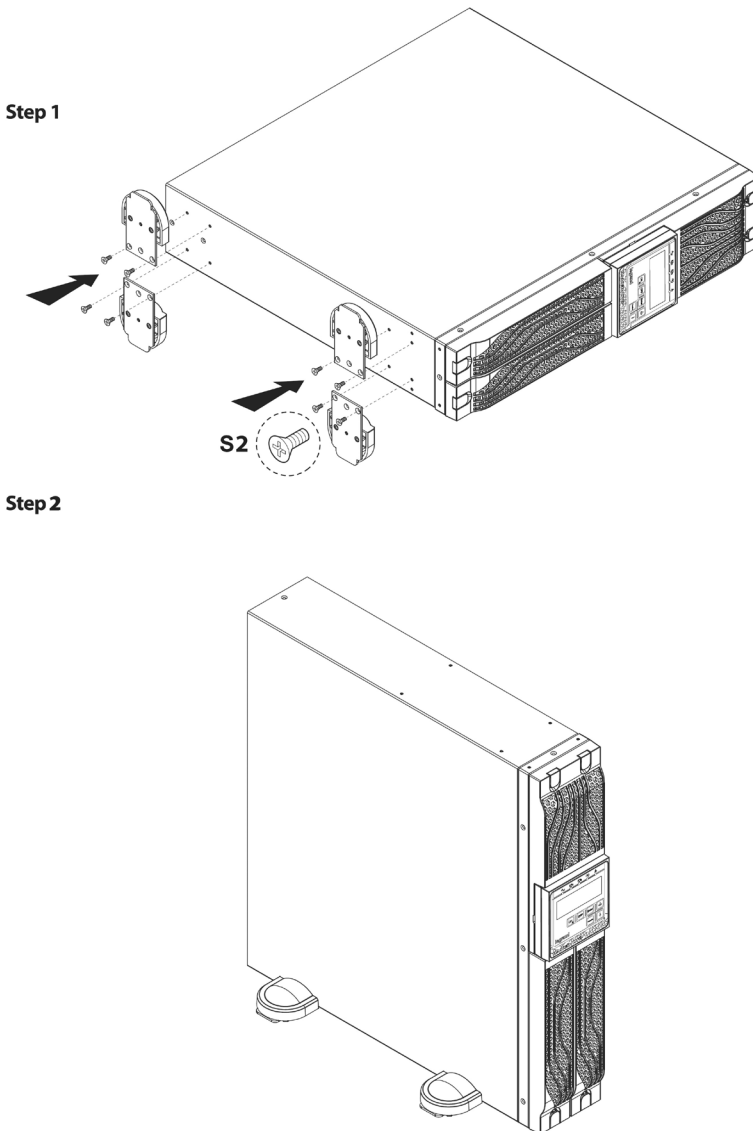

3.2.2 UPS + battery cabinet (optional)

Step 1

THIS PART COMES FROM THE BATTERY CABINET

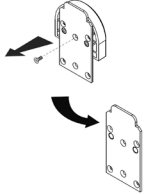

S2

x8: FROM UPS
x8: FROM BATTERY CABINET

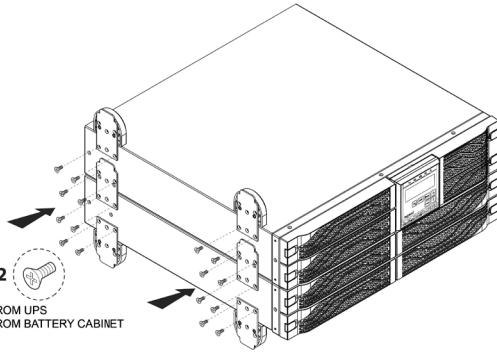

Step 2

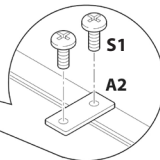
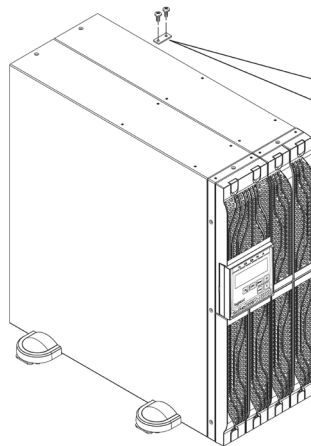

THIS PART COMES FROM THE BATTERY CABINET

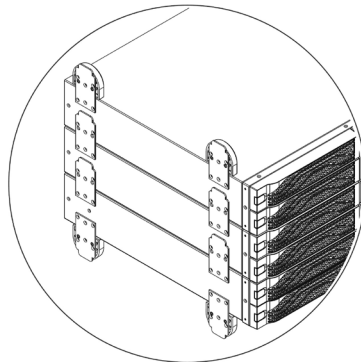
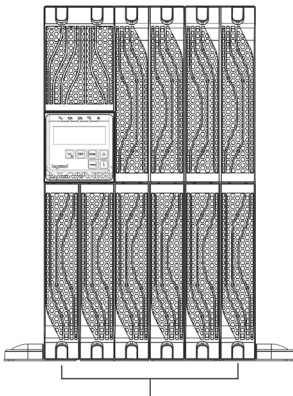

DAKER DK Plus 1 kVA - 2 kVA - 3 kVA

3.3 Rack configuration setup

INDICATION

For the rack configuration setup it is also possible to use the rack support bracket kit 3 109 52. In this case, follow the instruction sheet contained in the kit.

Step 1

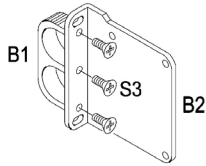

Step 2

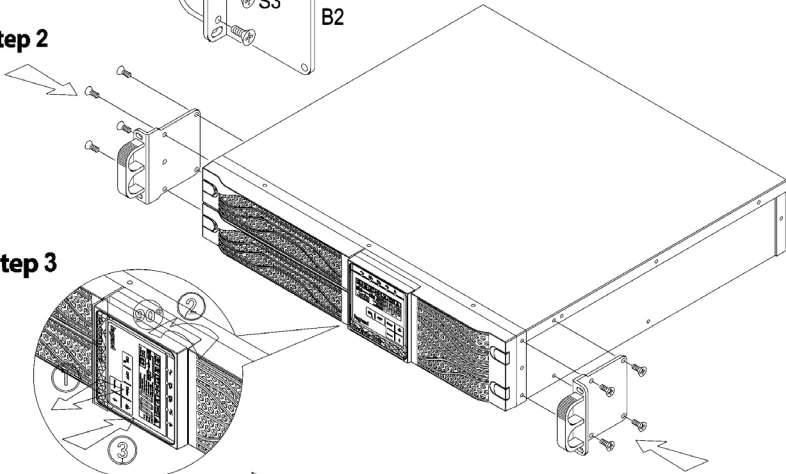

Step 3

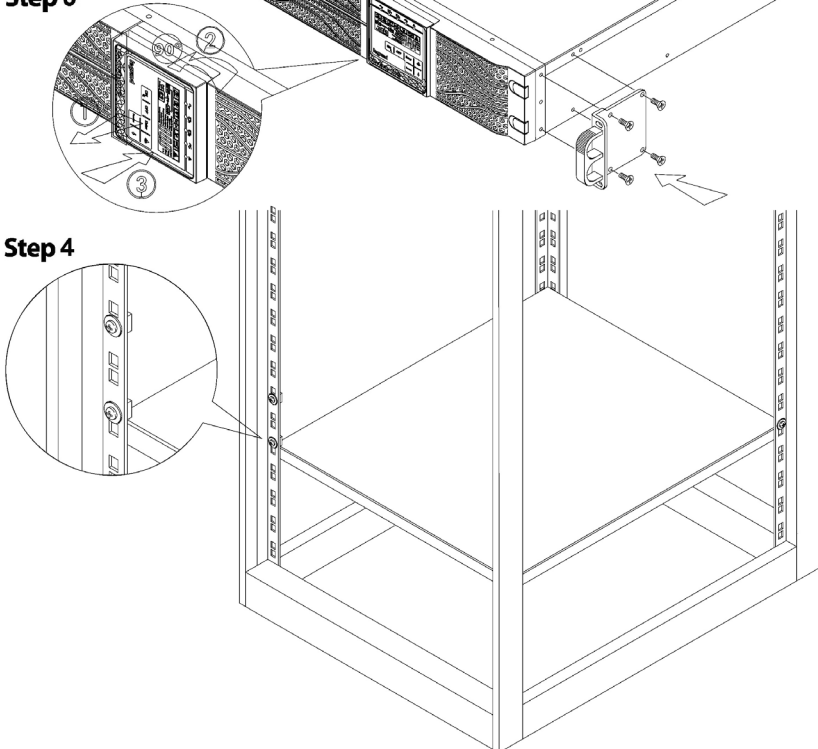

Step 4

Step 5

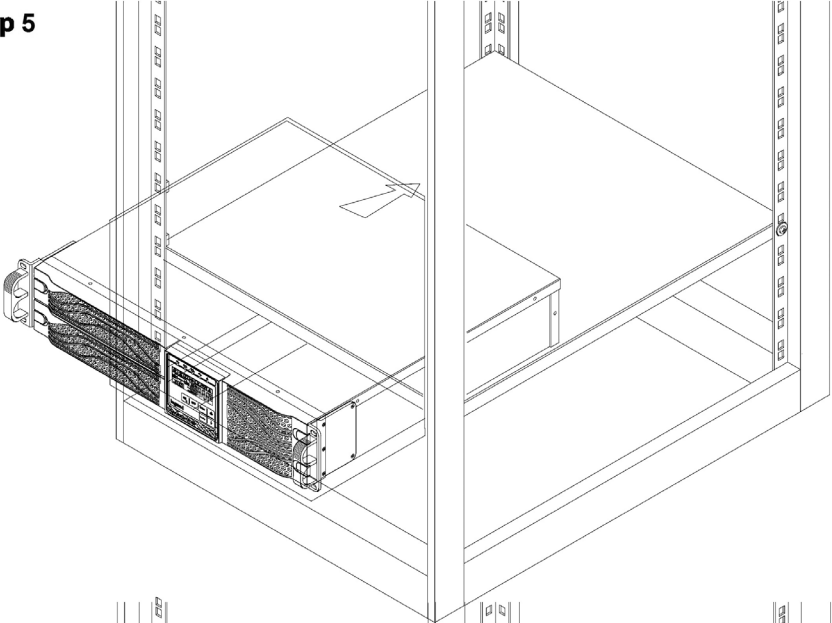

Step 6

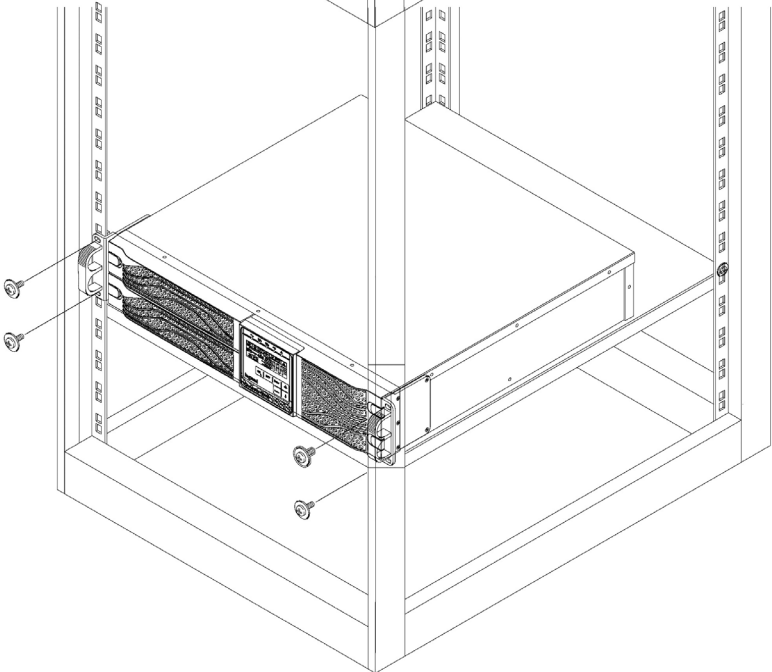

DAKER DK Plus 1 kVA - 2 kVA - 3 kVA

3.4 Rear panel

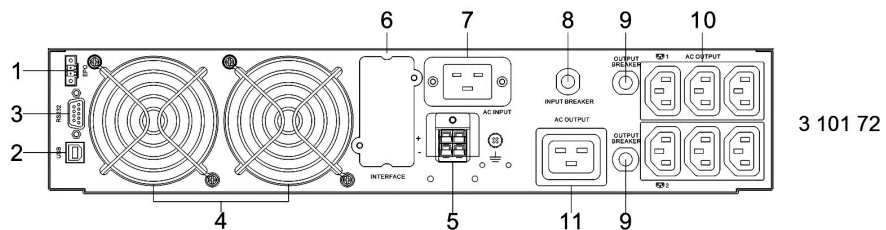
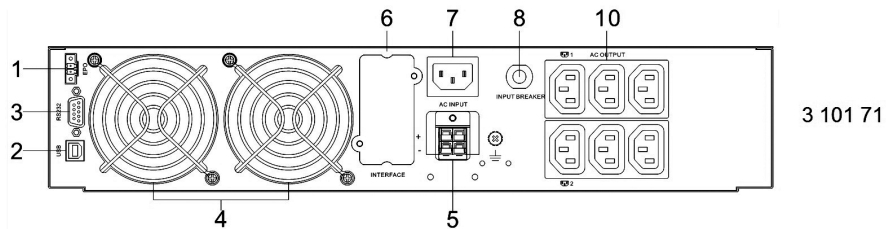
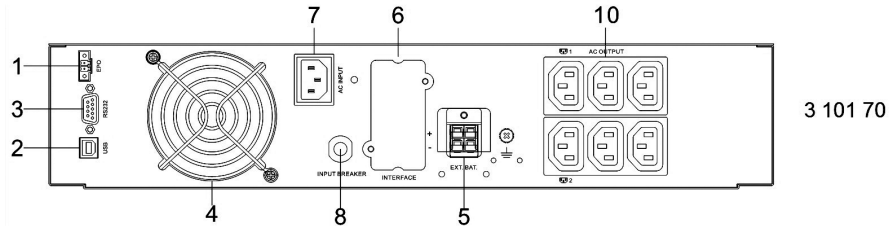

1. Emergency Power Off (EPO)
2. USB port
3. RS-232 port
4. Cooling fans
5. External battery connector
6. SNMP slot
7. AC input inlet
8. Input circuit breaker
9. Output circuit breakers
10. IEC type F outlets
11. IEC type J outlet

3.5 Installation procedure

**WARNING**

Read the safety instructions on chapter 2 before installing the UPS.

1. Position the UPS so that the cooling fans are not obstructed, as visible in the following figure:

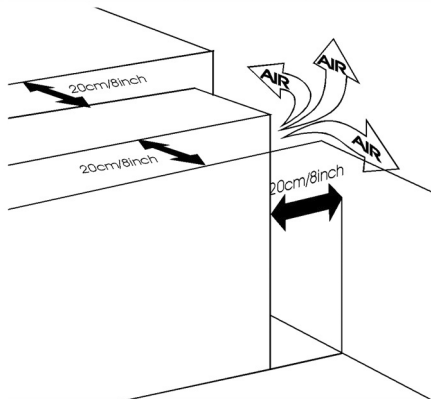

2. Connect the IEC input and output cables provided to the appropriate inlet and outlets.
3. Connect the loads to the IEC output cables, ensuring that the switches of the various loads are in the off position.
4. Plug the UPS input cable into a main socket with a suitable voltage and current.
5. Connect the EPO contact in the UPS (normally closed)

4 Operation

4.1 Control Panel

4.1.1 LCD Panel







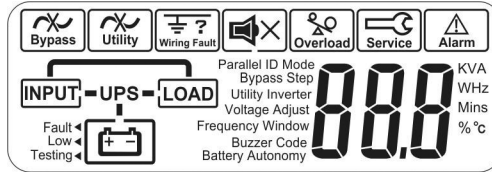

















ITEM	DESCRIPTION
①	Display
②	The steady green LED indicates that the mains voltage is within the admittable input voltage range
③ ④	The green LEDs indicate that the programmable outlets 1 and 2 are activated
⑤	The green LED blinks if the UPS is in bypass mode. The steady green LED indicates that the UPS is in ECO mode.
⑥	The steady red LED indicates that there is an alarm
⑦	UPS power ON/Silence alarm
⑧	UPS power OFF
⑨	Special functions access menu
⑩	Go to the next screen
⑪	Go to the previous screen or change the setting of the UPS
⑫	Confirm a changed setting

4.1.2 Display description



SIGN	DESCRIPTION
	Bypass Fault
	Utility Input Fault
	Site wiring Fault
	Buzzer Silent
	Overload
	UPS Service mode (reserved for LEGRAND Technical Support Service)
	Alarm
	UPS operation diagram
	3-Digit Measurement Display
	Measured item
Fault ◀	Battery fault
Low ◀	Battery low
Testing ◀	Battery test

4.2 Operating modes

UPS OPERATING MODE	LEDs/DISPLAY INDICATION	BUZZER
<p>NORMAL MODE on-line, double conversion</p>	<p>LEDs: steady , , </p> <p style="text-align: center;">LINE — UPS — LOAD</p> <p>DISPLAY: </p>	No sound
<p>STORED ENERGY MODE The loads are supplied through the batteries connected to the UPS</p>	<p>LEDs: steady , , </p> <p>DISPLAY:  LINE UPS — LOAD </p>	Beep every second
<p>BYPASS MODE The loads are supplied directly from the mains. The UPS does not protect the loads. The UPS is in bypass mode after a setting shortcut (paragraph 4.7), a generic alarm or a prolonged overload in normal mode.</p>	<p>LEDs: steady , , </p> <p style="text-align: center;">LINE — UPS — LOAD</p> <p>DISPLAY: </p>	Beep every two seconds
<p>ECO MODE The loads are supplied directly from the mains through the automatic bypass circuit inside the UPS. The output voltage and frequency are the same as the mains.</p>	<p>LEDs: steady , , , </p> <p style="text-align: center;">LINE — UPS — LOAD</p> <p>DISPLAY: </p>	No sound
<p>CVCF 50/60 The UPS maintains constant the output voltage and the output frequency to 50 Hz or 60 Hz according to the setting. With this operating mode it is available only the 75% of the nominal output power.</p>	<p>LEDs: steady , , </p> <p style="text-align: center;">LINE — UPS — LOAD</p> <p>DISPLAY: </p>	No sound

See also paragraph 4.6 to set the operating mode.



4.3 Start-up procedure

4.3.1 Normal mode

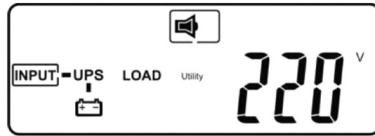
1. Make sure the input breaker is not tripped. If it is, reset it.
2. Plug the UPS input cable into the mains socket.
3. The UPS turns to the standby mode in 5 seconds. The green LED  lights up if the input voltage is within the admittable range and the fans spin. The battery charger is active. In this condition the loads are not powered. The display looks like the following figure:



4. Press  and hold it until the buzzer sounds twice.

The green LEDs   light up. The display looks like the following figure:

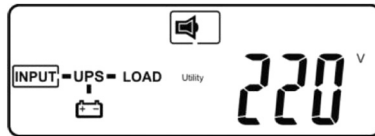

5. The start-up procedure is completed. Make sure that the batteries are fully charged or that the UPS has been plugged to the wall receptacle at least for 4 hours before connecting the loads.

4.3.2 Cold start

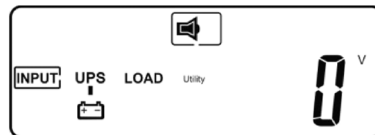

1. Make sure the internal batteries or the external battery cabinets are connected to the UPS.
2. Press  and hold it until the buzzer sounds twice; then release the key. The display looks like the following figure:



3. Press  again and hold it until the buzzer sounds twice. If the second key confirmation is not completed within 10 seconds, the UPS does not perform the cold start and shuts off.

DAKER DK Plus

1 kVA - 2 kVA - 3 kVA

4. Few seconds after the second key confirmation, the UPS turns on in stored energy mode and the loads are powered. The alarm LED  and the green LEDs   light up. It is audible an intermittent sound alarm.

The display looks like the following figure:

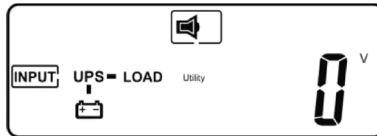



5. The start-up procedure is completed. If the UPS is not plugged to the mains outlet, the loads are powered till the end of the backup time.



INDICATION

The output frequency is the same that there was at the input before the UPS was shutdown. The default value is 50 Hz but if before the UPS shutdown the input frequency was 60 Hz, then the output frequency after the cold start will be 60 Hz.

4.4 Shutdown

1. Press and hold  until the buzzer sounds twice.
2. The UPS stops powering the loads and turns to the standby mode. The green LEDs   switch off. The ventilating fans continue spinning.
3. Unplug the UPS from the wall receptacle if there is still input voltage. After 10 seconds, the fans stop working and the UPS completely shuts down.

4.5 UPS Measurements

After the UPS is turned on, it is possible to check the UPS measurements by pressing  or .









The display sequence is:

- AC input voltage;
- AC input frequency;
- output voltage;
- output frequency;
- load percentage;
- output current;
- battery voltage;
- battery autonomy;
- UPS internal temperature;
- battery status.

4.6 UPS settings

After the UPS is turned on, it is possible to check the UPS settings by pressing **Function**. The different parameters can be scrolled pressing .

It is possible to change only three parameters while the UPS is supplying the loads. One of these is reserved to the LEGRAND Technical Support Service.

PARAMETER	SETTING	DISPLAY
BUZZER	ON	 Buzzer ON
	OFF	 Buzzer OFF
QUICK BATTERY TEST	OFF	 Testing • OFF
	ON	 Testing • ON
BATTERY STATUS TEST  This function is reserved to the LEGRAND Technical Support Service and must not be activated by the user	OFF	  Battery OFF
	ON	  Battery ON

DAKER DK Plus

1 kVA - 2 kVA - 3 kVA

Follow this procedure to change the buzzer setting:







- press the **Function**. The buzzer setting is displayed;
- press **↕** to select ON or OFF;
- confirm the choice by pressing **Function**.

The quick battery test can be performed to check the operation of the batteries. The test must be performed only after the batteries are fully charged, the mains is available and the UPS is powering the loads. Follow this procedure to perform the battery test:

- press **Function**;
- press **↓** to display the battery test setting;
- press **↕** to select ON. The UPS transfers to stored energy mode for 10 seconds. During the test, the loads are always powered with no voltage dip;
- if at the end of the test the UPS transfers back to normal mode without any alarm code, the batteries are working properly.

To change all the other settings, the UPS must be in standby mode. In this condition the loads are not powered, therefore all the needed settings must be performed before turning on the UPS. Follow this procedure to change the UPS settings:

- press simultaneously **ON** and **↓** for approximately three seconds, until the buzzer sounds twice. The LCD displays the first setting indicated in the next table ("buzzer");
- all the different settings can be scrolled pressing **↓**;
- except for the buzzer and the battery test, all the other settings may be changed by pressing **↕**;
- after changing settings, scroll to the "End" screen and then press **Enter** to save all changes;
- the UPS restarts automatically. However, it is also suggested to remove the mains for at least 30 seconds.



PARAMETER	SETTING	DISPLAY
BUZZER <i>(this setting can't be changed with this procedure)</i>	ON	 Buzzer ON
	OFF	 Buzzer OFF
QUICK BATTERY TEST <i>(this setting can't be changed with this procedure)</i>	OFF	 Testing * OFF
BATTERY STATUS TEST <i>(this setting can't be changed with this procedure and it is reserved to the LEGRAND Technical Support Service)</i>	OFF	  Battery OFF
BYPASS VOLTAGE RANGE	LOW The bypass voltage range is set to $\pm 15\%$ of the selected output voltage	 Bypass Voltage Window Lo
	HIGH The bypass voltage range is set to $\pm 10\%$ of the selected output voltage	 Bypass Voltage Window Hi

DAKER DK Plus

1 kVA - 2 kVA - 3 kVA

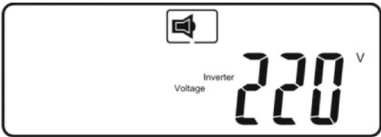
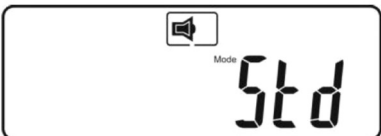
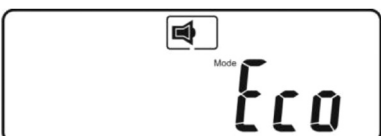
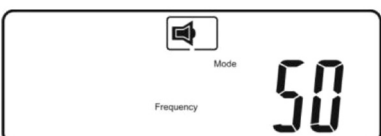
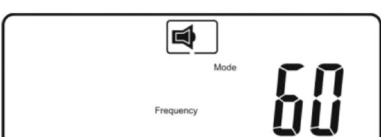
EN

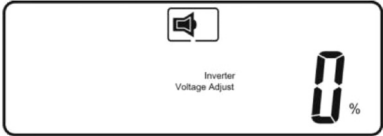
PARAMETER	SETTING	DISPLAY
BYPASS FREQUENCY RANGE	$\pm 1 \text{ Hz}$ $\pm 3 \text{ Hz}$ If during the normal functioning the bypass frequency goes beyond the setting, the UPS enters in lock mode (alarm and output disconnected)	 <p>The display shows a speaker icon, the word "Bypass", "Frequency Window", and the number "03" followed by "Hz".</p>
OUTPUT VOLTAGE	200 V 208 V 220 V 230 V 240 V	 <p>The display shows a speaker icon, the word "Inverter", "Voltage", and the number "220" followed by "V".</p>
OPERATING MODE (see paragraph 4.2)	NORMAL MODE	 <p>The display shows a speaker icon, the word "Mode", and the text "Std".</p>
	ECO MODE	 <p>The display shows a speaker icon, the word "Mode", and the text "Eco".</p>
	CVCF 50 Hz	 <p>The display shows a speaker icon, the word "Mode", "Frequency", and the number "50".</p>
	CVCF 60 Hz	 <p>The display shows a speaker icon, the word "Mode", "Frequency", and the number "60".</p>

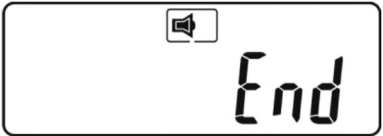









PARAMETER	SETTING	DISPLAY
OUTPUT VOLTAGE ADJUSTMENT	<p> 0 % - 1 % - 2 % - 3 % + 3 % + 2 % + 1 % </p> <p>If during the normal functioning of the UPS the output voltage is slightly below or above the desired value, this setting allows to adjust it</p>	
EXTERNAL BATTERY CABINETS	<p>1c - 9c</p> <p>Select the number of external battery cabinets connected to the UPS</p>	
END SCREEN	<p>Press Enter to save all changes</p>	

INDICATION

If the UPS is connected to one or more battery cabinets, it is necessary to set their number to forecast a realistic backup time. This can be done from the display of the UPS or by using the software "UPS Setting Tool".

4.7 Settings shortcuts

There are two settings shortcuts:

- Bypass Mode: while the UPS is in normal mode (on-line, double conversion) press  and  simultaneously for approximately three seconds, until the buzzer sounds twice. The UPS transfers from normal mode to bypass mode. During this functioning mode, the bypass LED  blinks and the buzzer sounds intermittently. Press again  and  simultaneously until the buzzer sounds twice to return to normal mode.
- Eco Mode: while the UPS is in normal mode (on-line, double conversion) press  and  simultaneously for approximately three seconds, until the buzzer sounds twice. The UPS transfers from normal mode to eco mode. During this functioning mode, the bypass LED  is on. Press again  and  simultaneously until the buzzer sounds twice to return to normal mode.

4.8 Emergency Power Off (EPO)

The UPS has an external normally closed contact that can be opened to activate the immediate stop of the UPS. It is possible to connect to each other several EPO contacts of UPS Daker DK Plus to a unique emergency pushbutton.

The EPO terminal is at the back of the UPS and it is needed for the functioning of the UPS.

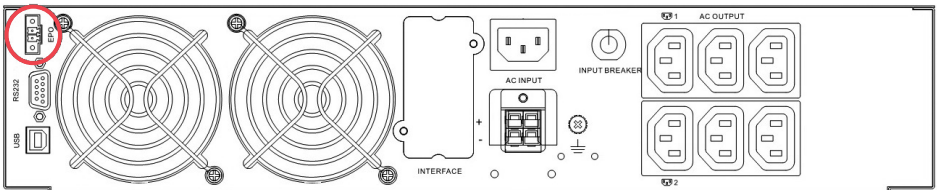

4.9 Communication devices

The UPS has one RS232 serial port, one USB port and one SNMP slot.

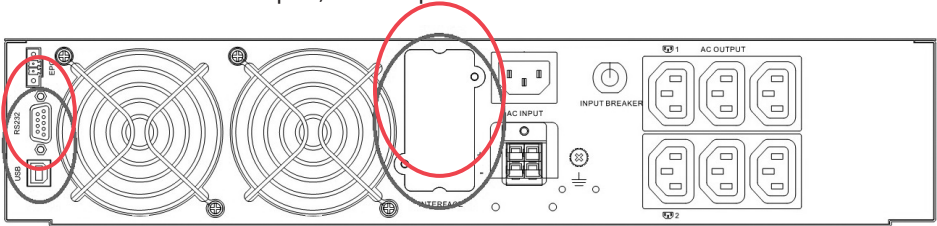

Only one communication interface at a time can control the UPS, according to the following priority:

- 1) optional interface card;
- 2) USB;
- 3) RS232.

The following figures show the pinout of the RS232 and USB interfaces:

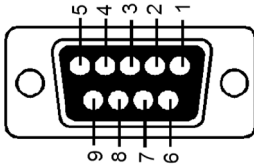

Pin 3: RS-232 Rx
 Pin 2: RS-232 Tx
 Pin 5: Ground

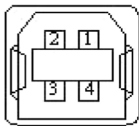





Pin 1: VCC (+5V)
 Pin 2: D-
 Pin 3: D+
 Pin 4: Ground

It is possible to download some free of charge software from the website <http://www.ups.legrand.com>

The software can be used for the following functions:

- display of all the operations and diagnostic data in case of problems (UPS Communicator);
- setup of special functions (UPS Setting Tool). For instance, the UPS has two programmable outputs for less critical loads. These sockets may be disabled or timed during stored energy mode to ensure the supply of the more critical loads;
- automatic shutdown of the local computer (UPS Communicator).

5 Troubleshooting

INDICATION	DIAGNOSTIC	SOLUTION
<p>Fault LED </p> <p>Check the error code on the display (see error code table)</p>	<p>Er05, Er39</p>  <p>intermittent sound alarm</p>	<p>The batteries don't work properly. Check for proper battery connection and measure battery voltage to ensure that batteries are charged. Recharge the batteries for 8 hours.</p> <p>If the problem persists or if it is necessary to replace them, contact the LEGRAND Technical Support Service.</p>
	<p>Er12</p>  <p>continuous alarm sound</p>	<p>Disconnect some non-critical loads from the UPS output until the overload ceases. Check if there is any short-circuit between the output cables due to a faulty insulation. Replace the cables if necessary.</p>
	<p>Site wiring/Ground fault</p> 	<p>Check if the power cord is properly plugged, respecting the "L" and "N" wires. If not, re-plug the cord on the socket turning it of 180°. If the power cord is properly plugged, check if the ground-neutral voltage exceeds the limits.</p>
	<p>Er11, Er14</p> <p>intermittent sound alarm</p>	<p>Verify that the ventilating fans work properly. If the problem persists or if it necessary to replace them, contact the LEGRAND Technical Support Service.</p>
	<p>other error codes</p>	<p>Check the error code table. If the problem persists, contact the LEGRAND Technical Support Service.</p>
<p>The UPS doesn't work in stored energy mode or the backup time is shorter than its intended performance.</p>	<p>-</p>	<p>If the backup time remains unsatisfactory after 8 hours of battery charging, contact the LEGRAND Technical Support Service.</p>
<p>The UPS is working normally but the loads are not powered</p>	<p>-</p>	<p>Check that all power cords are properly connected. If the problem persists, contact the LEGRAND Technical Support Service.</p>

INDICATION	DIAGNOSTIC	SOLUTION
The UPS switches into stored energy mode and then back into normal mode when a connected device is turned on or the UPS switches back and forth between the two modes.	-	A power strip could be connected to the UPS. Do not use it. See also if there is any damage to the utility wall receptacle or if the cord plug is faulty. Replace them if needed. If the problem persists, contact the LEGRAND Technical Support Service.
Strange noise or smell	-	Shut down immediately the UPS. Disconnect the mains and contact the LEGRAND Technical Support Service.
The UPS switches off after a total discharge of the batteries	-	The function of autorestart is enabled by default. When the mains is available, the UPS restarts in normal mode to supply the loads.

Error code table

ERROR CODE	MEANING
Er05	Battery weak or faulty
Er06	Output short-circuit
Er07	EPO mode
Er11	UPS over-temperature
Er12	Inverter overload
Er14	Fans out of order
Er28	Bypass overload
Er39	Battery problem during the start-up process of the UPS

6 Warehousing and dismantling

6.1 Warehousing

The UPS must be stored in an environment with a room temperature between +20°C (+68°F) and +25°C (+77°F) and humidity less than 90% (not condensing).

The batteries installed inside the UPS are lead/acid sealed and do not require maintenance (VRLA). The batteries should be charged for 12 hours every 3 months by connecting the UPS to the utility supply. Repeat this procedure every two months if the storage ambient temperature is above +25°C (+77°F).



CAUTION

The UPS must never be stored if the batteries are partially or totally discharged.

LEGRAND is not liable for any damage or bad functioning caused to the UPS by wrong warehousing.

6.2 Dismantling



DANGER

Dismantling and disposal operations may only be done by a qualified electrician. These instructions are to be considered indicative: in every country there are different regulations with regard to the disposal of electronic or hazardous waste such as batteries. It is necessary to strictly adhere to the standards in force in the country where the equipment is used.

Do not throw any component of the equipment in the ordinary rubbish.



Batteries must be disposed of in a site intended for the recovery of toxic waste. Disposal in the traditional rubbish is not allowed.

Pb

Apply to the competent agencies in your countries for the proper procedure.



WARNING

A battery may constitute a risk of an electric shock and high short-circuit current.

When working on batteries, the prescriptions indicated in chapter 2 are to be adhered to.

It is important to dismantle the various parts the UPS consists of. For these operations, Personal Protective Equipment must be worn.

Sub-divide the components separating the metal from the plastic, from the copper and so on according to the type of selective waste disposal in the country where the equipment is dismantled.

If the dismantled components must be stored before being properly disposed, be careful to keep them in a safe place protected from atmospheric agents to avoid soil and groundwater contamination.

For the disposal of electronic waste it is necessary to refer to the industry standards.



This symbol indicates that in order to prevent any negative effects on the environment and on people, this product should be disposed of separately from other household waste, by taking it to authorised collection centres, in accordance with the EU countries

local waste disposal legislations. Disposing of the product without following local regulations may be punished by law. It is recommended that you check that in your country this product is subject to WEEE legislations.

7 Technical specifications

	3 101 70 - 3 100 49	3 101 71 - 3 100 55	3 101 72 - 3 100 75
General characteristics			
Nominal power (VA)	1000	2000	3000
Active Power (W)	900	1800	2700
Technology	on-line, double conversion, VFI-SS-111		
Waveform	sinusoidal		
Bypass	internal automatic bypass external maintenance bypass (optional)		
Input characteristics			
Connection	IEC C14	IEC C14	IEC C20
Rated voltage	230 V		
Range of voltage	180 V - 300 V ; PF=0,9 150 V - 180 V ; PF=0,75 120 V - 150 V ; PF=0,6		
Rated frequency	50 / 60 Hz \pm 5 %		
Maximum current	6,8 A	13,6 A	20,0 A
Total harmonic distortion of the current	THDi < 7% at full linear load and normal voltage		
Power factor	\geq 0.99 (with full linear load)		
Number of phases	Single phase		
Output characteristics			
Outlets	(6) IEC type F	(6) IEC type F	(6) IEC type F + (1) IEC type J
Rated voltage	230 V \pm 1% adjustable to 200/208/220/230/240 V		
Rated frequency	50 / 60 Hz \pm 0,1%		
Crest factor	3:1		
Total harmonic distortion of the voltage	< 3% at full linear load < 7% at full non-linear load		
Efficiency	up to 90%	up to 91%	up to 92%
Overload capacity	105% continuous 120% for 30 seconds 150% for 10 seconds		
Number of phases	Single phase		
Batteries and battery charger characteristics			
Number of batteries	3	6	6
Battery type	Lead-acid sealed without maintenance (VRLA)		
Unitary capacity	12 Vdc - 7.2 Ah	12 Vdc - 7.2 Ah	12 Vdc - 9 Ah
Rated Battery Voltage	36 Vdc	72 Vdc	72 Vdc

DAKER DK Plus

1 kVA - 2 kVA - 3 kVA

EN

	3 101 70 - 3 100 49	3 101 71 - 3 100 55	3 101 72 - 3 100 75
Backup time with 50% linear load	> 10 min	> 10 min	> 8 min
Battery extension	Yes		
Maximum charge current	2.1 Adc	1.5 Adc	1.5 Adc
Recharge time (to 90%)	4 hours		
Communication and management			
Screen and signalling	six pushbuttons and five LEDs for real-time control of the status and the main parameters of the UPS		
Communications ports	RS232 and USB Connector for network interface		
Software	Software for Windows and Linux environments is available in order to: - displaying all the functioning and diagnostic data in case of problems; - setup of special functions. Download a copy free of charge from the website http://www.ups.legrand.com		
Protections	Against overloads and short-circuit Backfeed Emergency Power Off (EPO) Overtemperature		
Mechanical characteristics			
Dimensions W x H x D (mm)	440 x 88 (2U) x 405	440 x 88 (2U) x 600	
Net weight (kg)	16	29,5	30
Environmental conditions			
Operating temperature	+20 °C to +40 °C +32 °F to +104 °F		
Operating relative humidity	20% to 80% (non-condensing)		
Storage temperature	+20 °C to +25 °C + 68 °F to +77 °F		
Noise level at 1 m	< 50 dB		
IP code	IP 20		
Heat dissipation (BTU/h)	490	654	818
Reference directive and standards			
Safety	2014/35/EU Directive EN 62040-1		
EMC	2014/30/EU Directive EN 62040-2		
Performance and test requirements	EN 62040-3		



WARNING: A battery can present a risk of electrical shock and high short circuit current. Only electrical hazard authorized personnel and service personnel are authorized to replace the batteries. Before the replacement, it is mandatory the reading of chapter 2. Batteries may only be replaced with the same number and type. Batteries must be brand new and the voltage difference between the strings must be less than 1V. If the battery brand is different from the one originally installed by Legrand, the estimated battery autonomy indicated on the display of the UPS may not be reliable.

INDICATION

Follow the instructions in the appendix at the end of the manual.